

<http://dx.doi.org/10.35630/2199-885X/2020/10/2.5>

# METHOD OF NEAR-FIELD DIELECTROMETRY OF BIOLOGICAL FLUID

Received 03 February 2020;  
Received in revised form 21 April 2020;  
Accepted 30 April 2020

Andrew Martusevich<sup>1,2✉</sup> , Alexander Galka<sup>1,3</sup> ,  
Elena Golygina<sup>1</sup>, Aleksandr Tuzhilkin<sup>2</sup> ,  
Alexandra Fedotova<sup>2</sup> 

<sup>1</sup> Privolzhsky Research Medical University,

<sup>2</sup> Nizhny Novgorod State Agricultural Academy,

<sup>3</sup> Institute of Applied Physics, Nizhny Novgorod, Russia

✉ [cryst-mart@yandex.ru](mailto:cryst-mart@yandex.ru)

**ABSTRACT** — The purpose of the work was to study the possibilities of near-field microwave dielectrometry. It is established that the developed device, using the principle of near-field resonant microwave sensing, allows performing the dielectrometry of biological fluid (on the example of blood). With the use of this technology, approximate standards of the dielectric constant of whole blood were formed. The presence of age-related features of the parameter level was demonstrated in this study.

**KEYWORDS** — microwave dielectrometry, dielectric permittivity, blood.

Over the past 30 years, a certain amount of data has been accumulated describing the dielectric properties of blood. It is shown that the dielectric properties of biopolymers can be used for evaluating the functioning of biological objects [2, 4, 7], for screening diagnostics of neoplasms [3], diabetes mellitus [4] etc.

Several studies have measured the dielectric properties of erythrocytes and plasma in the range 10 kHz–250 MHz, temperature dependence of electrodynamic parameters of blood is installed in the range of 1 Hz–40 GHz [1, 6, 7]. In addition, measurements of the dielectric characteristics of blood in a wide frequency range revealed numerous physical properties of macromolecules and their fragments [1, 5, 7]. On the other hand, the question of an unambiguous interpretation of these measurements and their relationship to the mechanisms of intracellular interaction remains open and questionable [6, 7]. According to modern concepts, many metabolic and functional changes in cells that accompany various pathological processes are determined by structural disorders of intra- and extracellular water [1, 5]. At the same time, laboratory and diagnostic prospects of equipment for assessing the dielectric characteristics of biological fluids have not been disclosed. In this

regard, the purpose of the work was to study the possibilities of near-field microwave dielectrometry.

## MATERIAL AND METHODS

Our measuring system for studying the dielectric properties of blood is a high-quality microwave resonator made on a segment of a coaxial line with a fluoroplast filling. At one end of the resonator there is a magnetic frame, the other is connected to the load, which includes a probing near-field antenna. The experimental setup scheme is shown in Fig. 1.

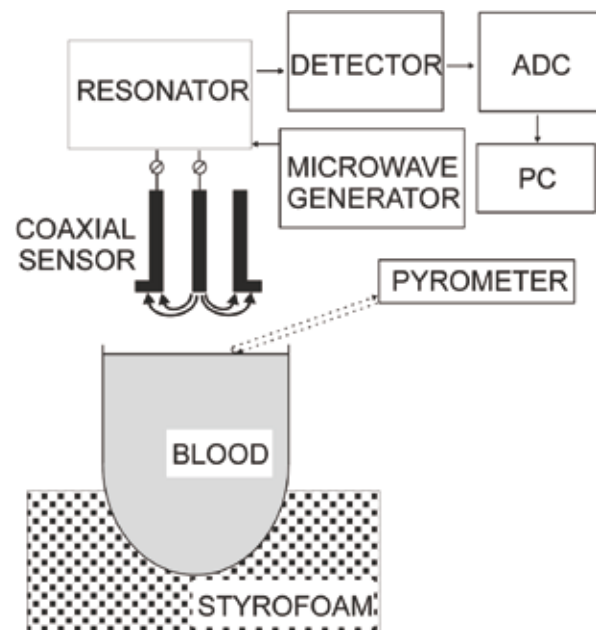

Fig. 1. Device for near-field microwave dielectrometry of liquids (principal scheme)

Due to the small transverse dimensions of the sensor, a relatively small volume of blood (50–100  $\mu$ l) was used. The distance from the end of the sensor to the bottom and to the side walls of the cell was fixed (about 3 mm), which is obviously more than the distance between the internal and external conductors. In this regard, the inaccuracy of standing of the sensor in the cuvette led to insignificant errors (no more than 1–2%) in measuring the permittivity. The electrodynamic parameters of the biological fluid were restored in the near-field antenna region by shifting the

resonant frequency and decreasing the signal amplitude during resonance. Alcohol with a known complex permittivity was used as the calibration control. Temperature control was performed using a pyrometer.

The developed complex was tested on whole blood samples of 35 adults (age — 20–45 years) and 25 children (age — 10–14 years) who did not have acute or chronic pathology at the time of the study. The material was obtained with the informed consent of the patients or their legal representatives.

The results were processed using the Statistica 6.0 program.

## RESULTS

Our research allowed us to demonstrate the possibility of evaluating the dielectric characteristics of biological fluid on the example of blood, as well as to form standards for the dielectric properties (permittivity and conductivity) of whole blood in children and adults (Fig. 2).

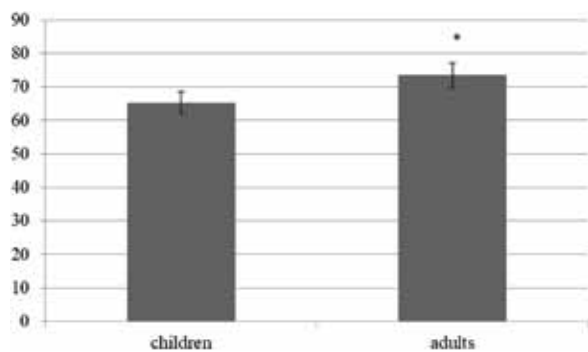

Fig. 2. The level of dielectric permittivity of the blood in children and adults, \* — the statistical significance of differences  $p < 0.05$

It was found that the dielectric permittivity of biofluid in humans is determined in the range of 40–75 units, and in healthy adults the parameter is detected at higher values ( $p < 0.05$ ).

## CONCLUSION

It was shown that the developed device, using the principle of near-field resonant microwave sensing, allows conducting dielectrometry of biological fluid (on the example of blood). With the use of this technology, we developed approximate standards of the dielectric constant of whole blood. The presence of age-related features of the parameter level was revealed in this study.

## REFERENCES

1. BEHREND S R., FUCHS K., KAATZE U. ET AL. Dielectric properties of glycerol/water mixtures

at temperatures between 10° C and 50° C. // J. Chem. Phys. – 2006. – Vol. 124. – P. 144512. DOI: 10.1063/1.2188391

2. KOUTSOUPIDOU M., KALLOS E., CANO-GARCIA H., PRICCI R.L., SAHA S.C., RANA S., ANCU O., DRAICCHIO F., MACKENZIE R., KOSMAS P. Dielectric permittivity of human blood of different lactate levels measured at millimeter waves // Conf Proc IEEE Eng Med Biol Soc. 2019. – Vol. 2019. – P. 1183–1186. doi: 10.1109/EMBC.2019.8857488
1. LIEWEI S. A review of dielectric properties of normal and malignant breast tissue // Proceedings IEEE SouthEastCon. – 2002. – P. 457–462. DOI: 10.1109/SECON.2002.995639
2. MARTUSEVICH A.K., YANIN D.V., BOGOMOLOVA E.B., GALK A.G., KLEMENOVA I.A., KOSTROV A.V. Possibilities and prospects of using microwave tomography in skin condition assessment // Biomedical Radioelectronics. – 2017 (12). – P. 3–12.
3. PARKHOMENKO M.P., SAVEL'EV S.V., GRO TOWSKI S.V. Investigation of dielectric properties of blood and the development of the resonator technique for non-invasive measurement of glucose in blood // Radio engineering and electronics. – 2017. – Vol. 62 (3) – P. 276–291.
4. ROSSMANNA C, HAEMMERICH D. Review of temperature dependence of thermal properties, dielectric properties, and perfusion of biological tissues at hyperthermic and ablation temperatures // Crit Rev Biomed Eng. – 2014. – Vol. 42(6). – P. 467–492. doi: 10.1615/critrevbiomedeng.2015012486.
5. WOLF M., GULICH R., LUNKENHEIMER P., LOIDL A. Broadband dielectric spectroscopy on human blood // Biochimica et Biophysica Acta. – 2011. – 1810(8) – P. 727–740.